

celsia.com



CELSIA

La energía que quieres

# Granjas SFV + BESS

 GRUPO ARGOS  
Inversiones que transforman



90 AÑOS



**CELSIA**

La energía que quieres





"The future is bright for energy storage. If you want more renewables on the grid, you need more batteries. It's not going to work otherwise."

*Andrés Gluski, Chief Executive - AES Corporation*

"We're just at the beginning of this,"

*Ross D - CAISO*

# ■ El almacenamiento en CELSIA





# La Tecnología

# ■ ¿Cuál química?

## LFP

“To hold +85% market share by 2030”

Fuente: BNEF

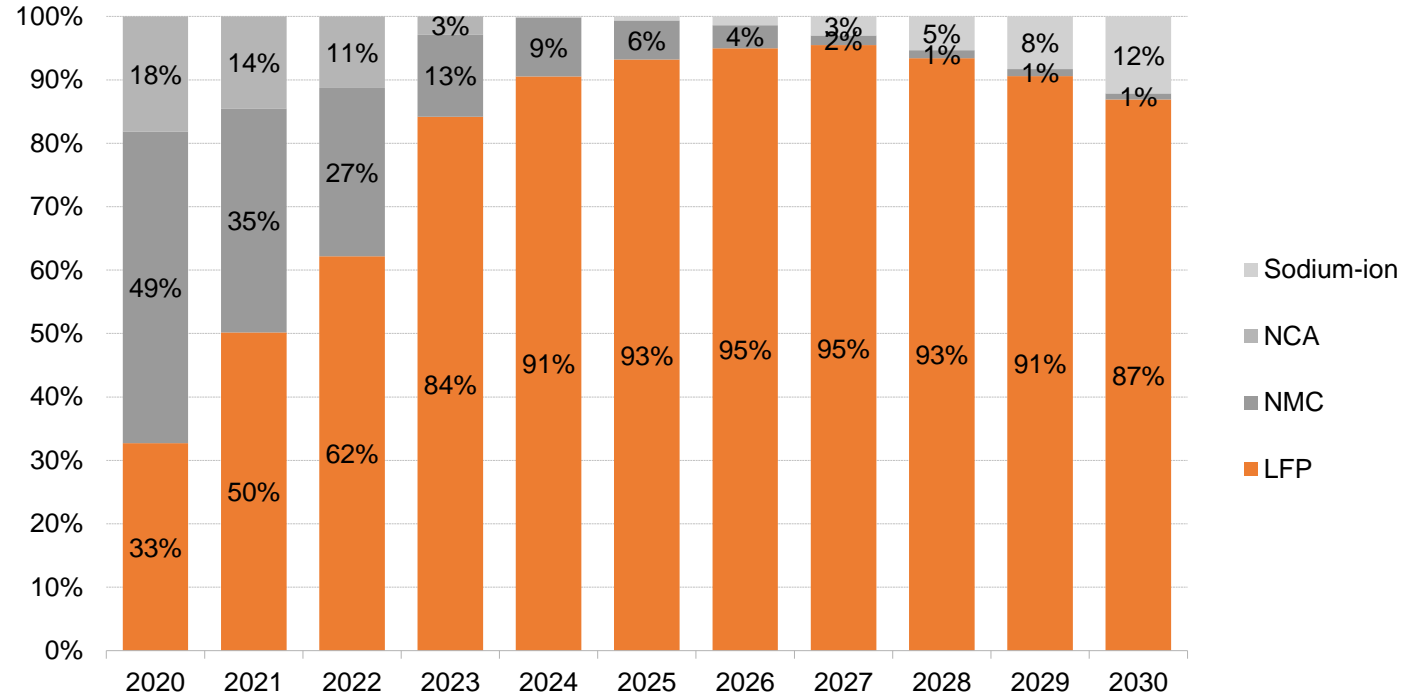

“Lithium-ion batteries using nickel manganese cobalt (NMC) is losing market share to *lithium iron phosphate (LFP) batteries*”

# ■ ¿Cuál química?

## LMO

*Litio Oxido de Manganeo*

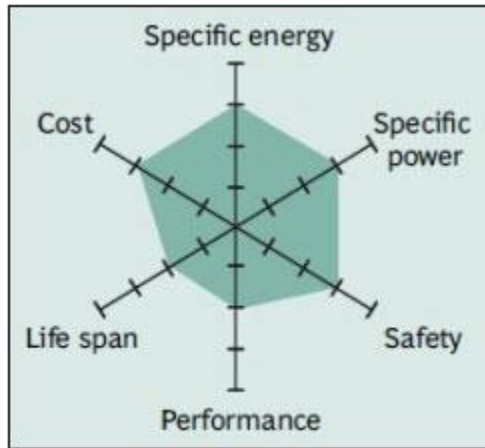

## NCA

*Niquel Cobalto Aluminio*

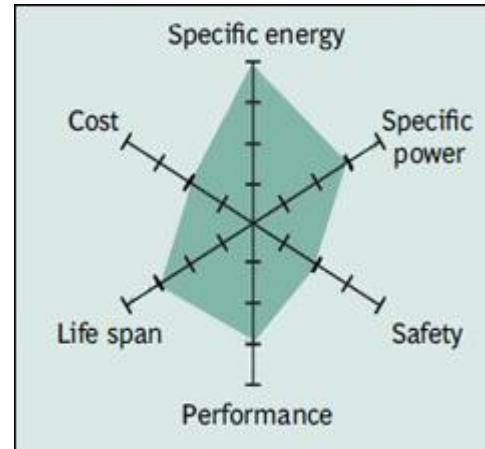

## NMC

*Niquel Manganeso Cobalto*

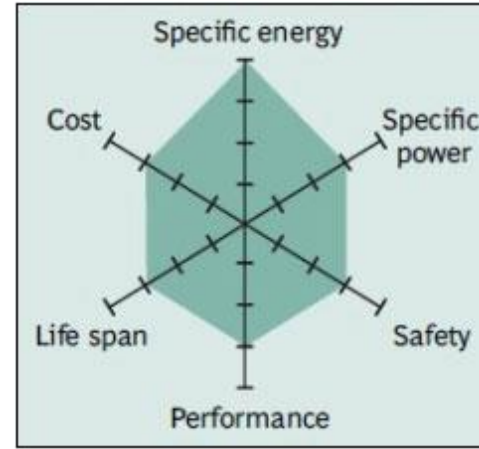

## LFP

*Litio Hierro Fosfato*

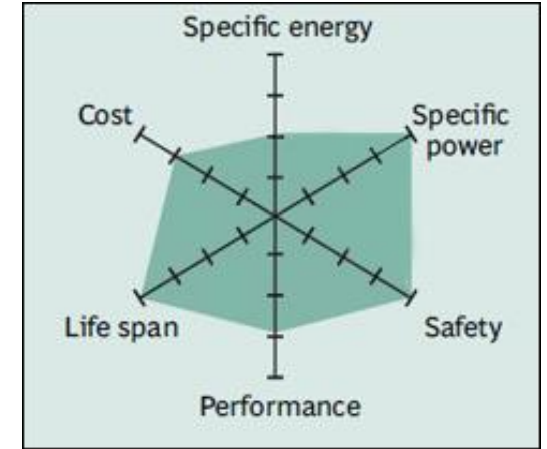

Fuente: Battery University

## ■ ¿Cómo es el activo?



**Solución utility  
scale**

**2-5 MWh**

**< 42 ton**



# ¿Cómo es el activo?

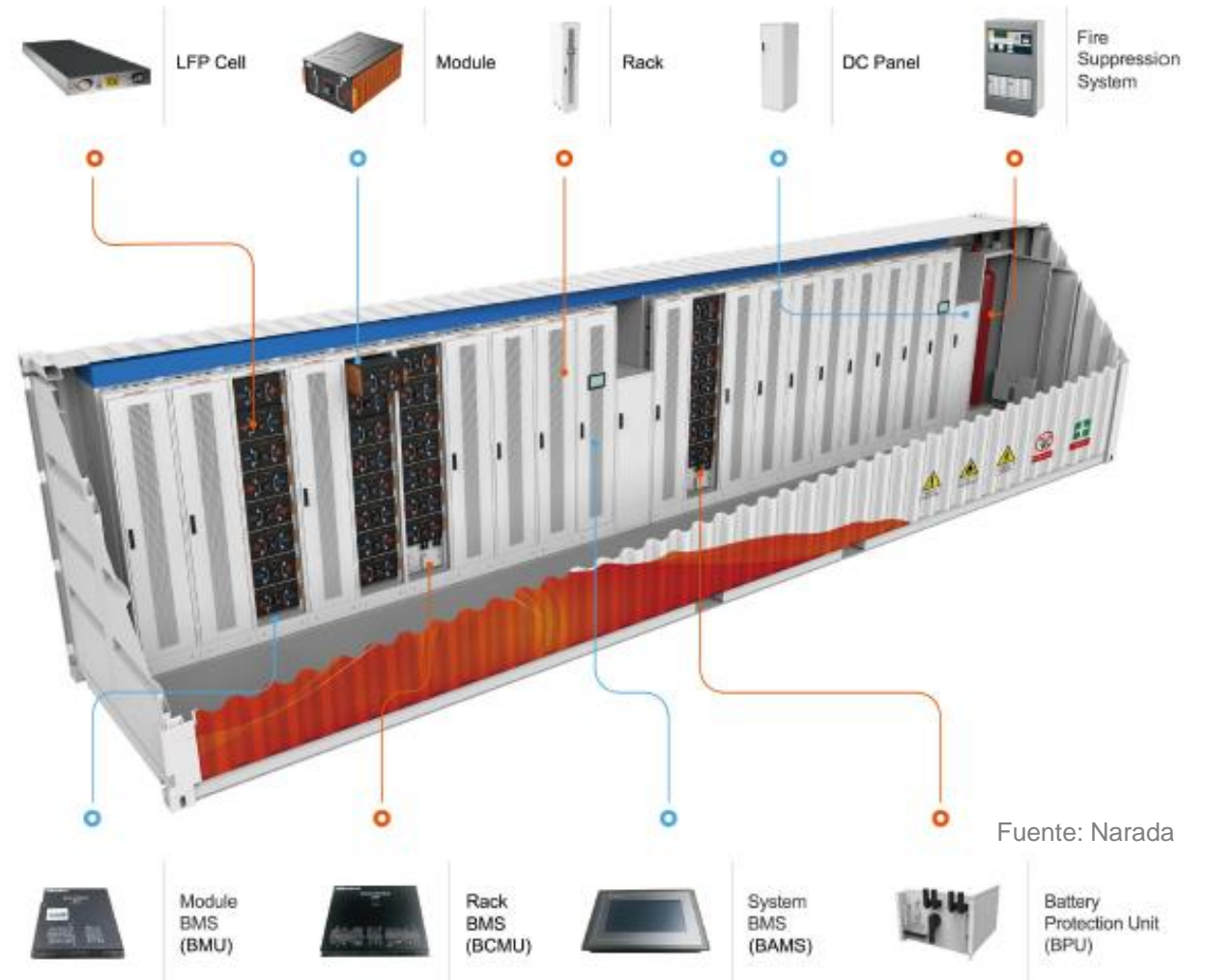
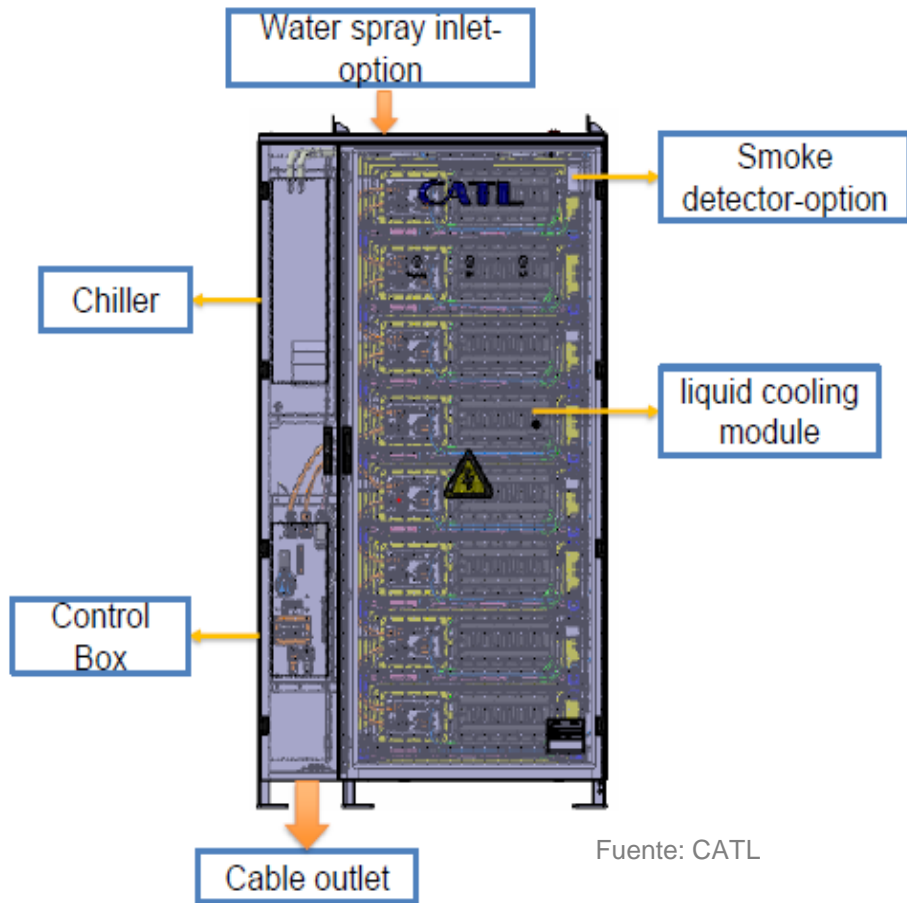

# ■ ¿Que ofrece?

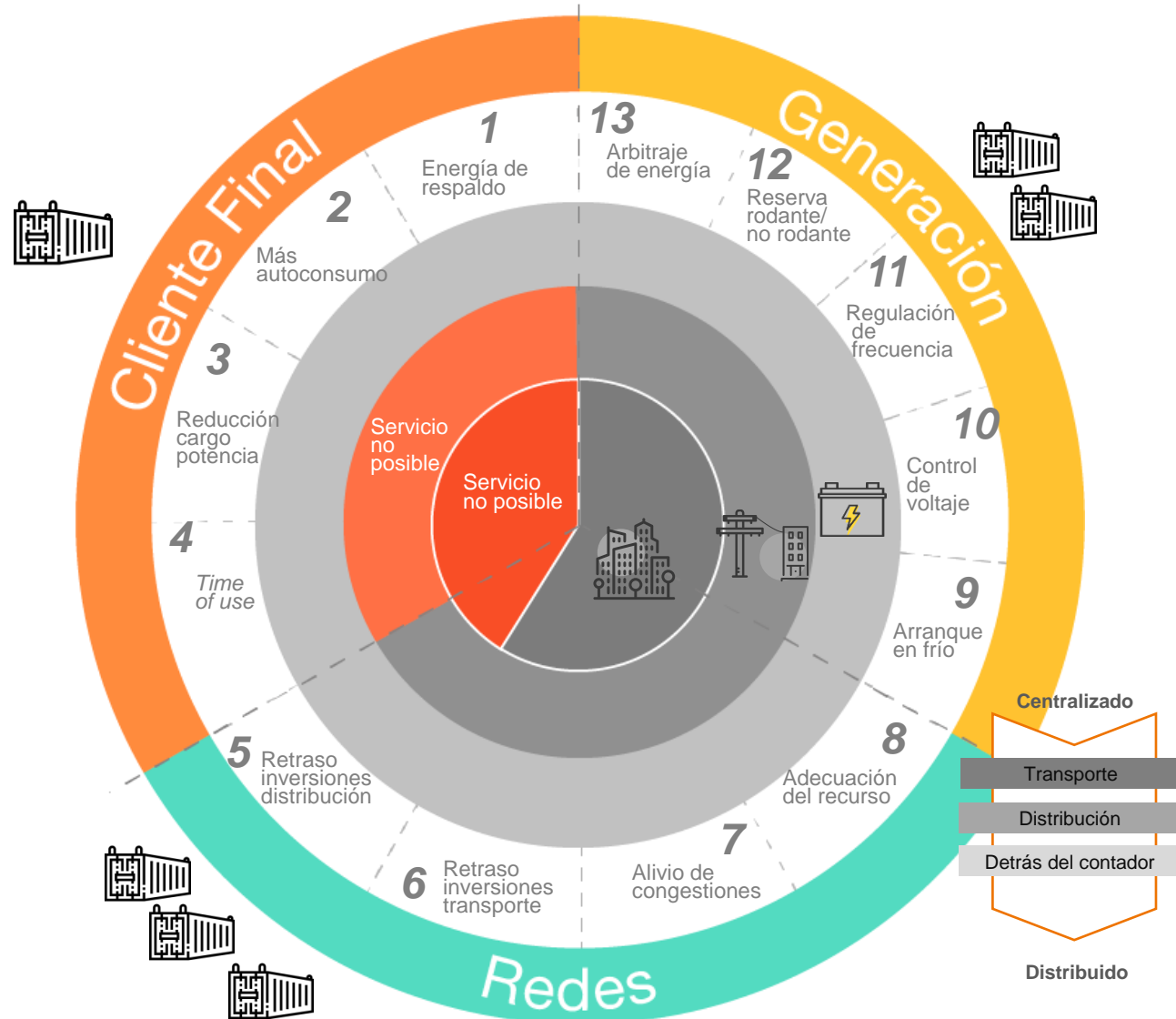



**¿Que se instala?**

# ■ Tipo de integración

## Integración AC

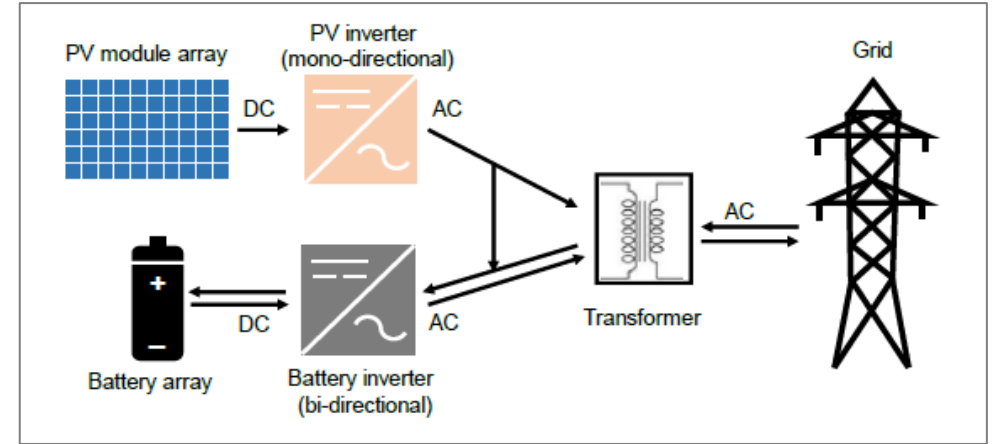
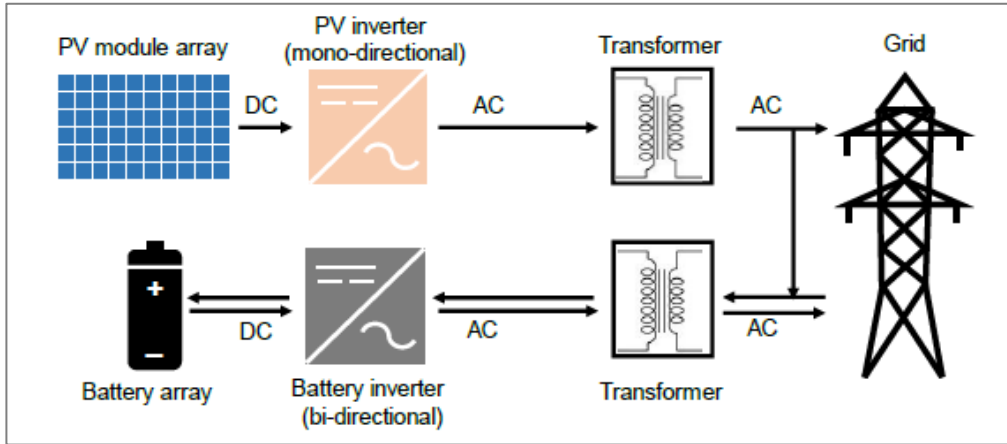

## Integración DC

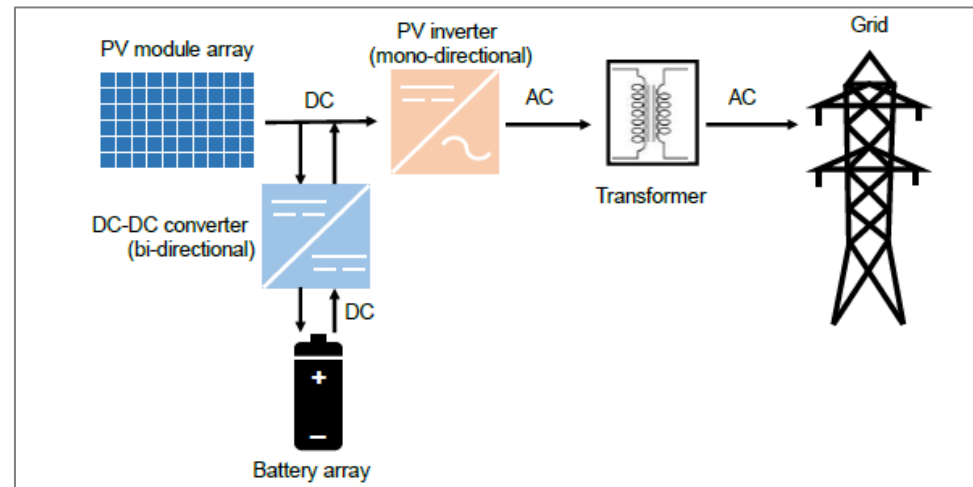

# Conexión Integración AC

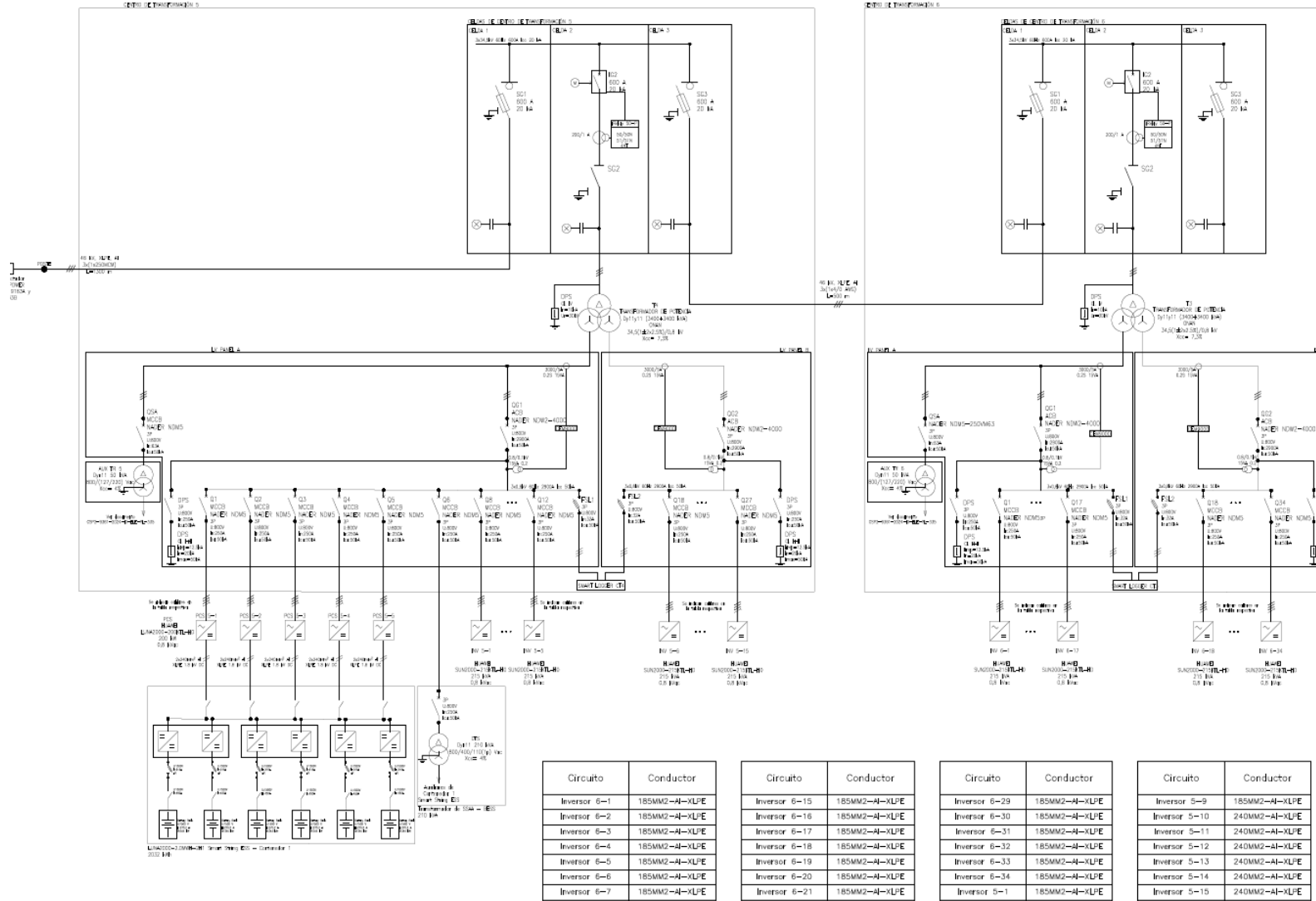

Circuito	Conductor
Inversor 5-1	185MM2-AI-XLPE
Inversor 5-2	185MM2-AI-XLPE
Inversor 5-3	185MM2-AI-XLPE
Inversor 5-4	185MM2-AI-XLPE
Inversor 5-5	185MM2-AI-XLPE
Inversor 5-6	185MM2-AI-XLPE
Inversor 5-7	185MM2-AI-XLPE

Circuito	Conductor
Inversor 5-8	185MM2-AI-XLPE
Inversor 5-9	185MM2-AI-XLPE
Inversor 5-10	240MM2-AI-XLPE
Inversor 5-11	240MM2-AI-XLPE
Inversor 5-12	240MM2-AI-XLPE
Inversor 5-13	240MM2-AI-XLPE
Inversor 5-14	240MM2-AI-XLPE
Inversor 5-15	240MM2-AI-XLPE

Circuito	Conductor
Inversor 5-16	185MM2-AI-XLPE
Inversor 5-17	185MM2-AI-XLPE
Inversor 5-18	185MM2-AI-XLPE
Inversor 5-19	185MM2-AI-XLPE
Inversor 5-20	185MM2-AI-XLPE
Inversor 5-21	185MM2-AI-XLPE
Inversor 5-22	185MM2-AI-XLPE
Inversor 5-23	185MM2-AI-XLPE
Inversor 5-24	185MM2-AI-XLPE

Circuito	Conductor
Inversor 5-25	185MM2-AI-XLPE
Inversor 5-26	185MM2-AI-XLPE
Inversor 5-27	185MM2-AI-XLPE
Inversor 5-28	185MM2-AI-XLPE
Inversor 5-29	185MM2-AI-XLPE
Inversor 5-30	185MM2-AI-XLPE
Inversor 5-31	185MM2-AI-XLPE
Inversor 5-32	185MM2-AI-XLPE
Inversor 5-33	185MM2-AI-XLPE
Inversor 5-34	185MM2-AI-XLPE

# Conexión Integración DC

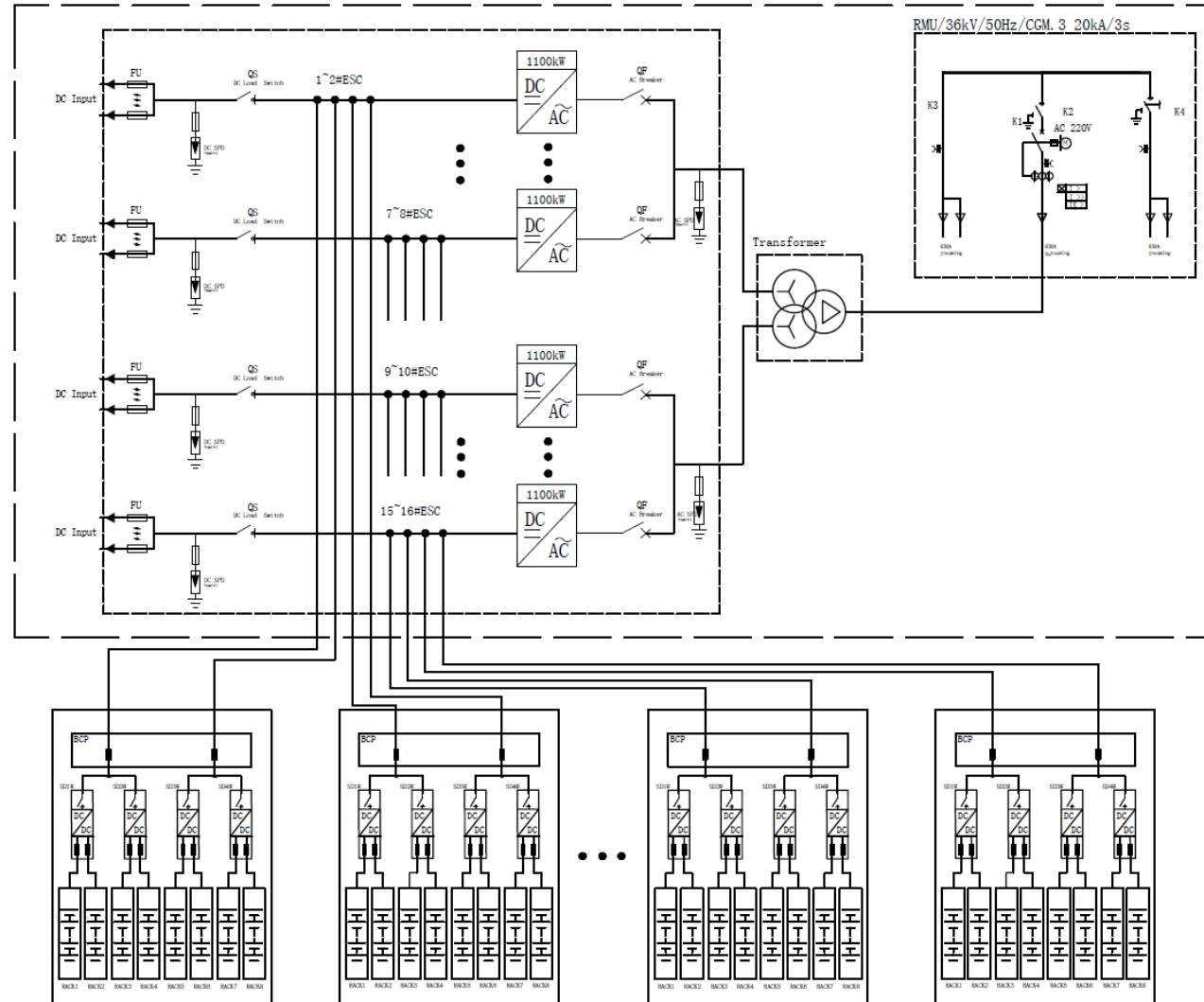



# Preguntas



CELSIA

La energía que quieres